

SMD Single high-speed RS485 isolated transceiver module



RoHS



### FEATURES

- Small size, SMD package
- Integrated high efficiency isolated DC/DC converter
- Two- port isolation (3.0kVDC)
- High baud rate up to 200kbps
- Operating temperature range: -40°C to +85°C
- The bus is able to support 64 nodes at maximum
- Set isolation and ESD bus protection in one
- EN60950 approval

TD321S485H / TD521S485H, the main function is to convert the logic level RS485 protocol differential level, to achieve signal isolation; is a use of IC integration technology to achieve the power isolation, signal isolation, RS485 communication and bus protection in one of the RS485 Protocol transceiver module. The product comes with constant voltage isolation power supply, can achieve 3000VDC electrical isolation. Products using SMD packaging technology, enabling customers to easily automated processing. Products can be easily embedded user equipment, the device easily RS485 protocol network connection.

### Selection Guide

Certification	Part No.	Mark	Power input (VDC)	Baud rate (kbps)	Static Current (mA)	Max. Operating Current (mA)	Isolation power output (typ.)(VDC)	Number of Nodes
CE	TD321S485H	321SRH	3.15-3.45	200	28	130	5	64
	TD521S485H	521SRH	4.75-5.25	200	38	130	5	64

### Limit Specifications

Item	Operating Conditions	Min.	Typ.	Max.	Unit
Input Surge Voltage (1sec.max.)	3.3V series	-0.7	--	5	VDC
	5.0V series	-0.7	--	7	
Pin Welding Resistance Temperature	Welding time: 10s (Max.)	--	--	300	°C
Reflow Soldering Temperature	Peak temp. ≤245°C, maximum duration time ≤60s at 217°C. For actual application, please refer to IPC/JEDEC J-STD-020D.1.				

### Input Specifications(3.3V series)

Item	Symbol	Min.	Typ.	Max.	Unit
Power Supply Input Voltage	VCC	3.15	3.3	3.45	VDC
TXD Logic Level	High-level	V <sub>IH</sub>	0.7V <sub>CC</sub>	3.3	
	Low-level	V <sub>IL</sub>	0	0.8	
RXD Logic Level	High-level	V <sub>OH</sub>	V <sub>CC</sub> -0.4	3.1	
	Low-level	V <sub>OL</sub>	0	0.2	
TXD Drive Current	I <sub>T</sub>	2	--	--	mA
CON Drive Current	I <sub>CON</sub>	--	--	5	
RXD Output Current	I <sub>R</sub>	--	--	2	
Serial Interface	Compatible with + 3.3 V UART interface only				

### Input Specifications(5.0V series)

Item	Symbol	Min.	Typ.	Max.	Unit
Power Supply Input Voltage	VCC	4.75	5	5.25	VDC
TXD Logic Level	High-level	V <sub>IH</sub>	0.7V <sub>CC</sub>	5	
	Low-level	V <sub>IL</sub>	0	0.8	
RXD Logic Level	High-level	V <sub>OH</sub>	V <sub>CC</sub> -0.4	4.8	
	Low-level	V <sub>OL</sub>	--	0.2	
TXD Drive Current	I <sub>T</sub>	2	--	--	mA
CON Drive Current	I <sub>CON</sub>	--	--	5	
RXD Output Current	I <sub>R</sub>	--	--	2	
Serial Interface	Compatible with + 5 V UART interface only				

### Transmission Specifications

Item	Symbol	Min.	Typ.	Max.	Unit
Data Delay	TXD Transmit Delay	tr	--	110	ns
	RXD Receive Delay	tr	--	110	
Handoff Delay		--	5	18	μs

### Output Specifications

Item	Symbol	Min.	Typ.	Max.	Unit
Difference Level	$V_{diff(c)}, R_L=54\Omega$	1.5	2	--	VDC
Difference load resistance		54	--	--	Ω
Difference Input Impedance	$-7V \leq V_{CM} \leq +12V$	96	--	--	kΩ
Built-in pull-down resistor		--	24	--	
Isolation power output voltage*	Nominal input voltage	4.9	5	5.3	VDC
Bus Interface Protection		ESD protection			

Note: \*Isolated output power pins are only available for external pull-up, pull-down resistors (recommended maximum current <25mA), not recommended for other purposes.

### Truth Table Specifications

Transceiver Control	Input		Output		
	CON	TXD	A	B	RXD
Send status	0	1	1	0	1
	0	0	0	1	1
Receive status	CON	$V_A - V_B$	RXD		
	1	$\geq -50mV$	1		
	1	$\leq -200mV$	0		
	1	$-200mV < V_A - V_B < -50mV$	Uncertain state		

### General Specifications

Item	Operating Conditions	Value
Isolation Voltage	Testing for 1 minute, leakage current <1mA	3000VDC
Insulation Resistance	Isolation voltage 500VDC	1000MΩ (input-output)
Operating Temperature		-40°C to +85°C
Transportation and Storage Temperature		-50°C to +105°C
Operating Humidity	Non-condensing	10% - 90%
Safety Standard		EN60950
Safety Certification		
Safety Class		CLASS III

### Physical Specifications

Dimensions	SMD 10
Weight	1.90g (Typ.)
Cooling Method	Free air convection

### EMC Specifications

EMI	CE	CISPR32/EN55032	CLASS A (see Fig. 3)
EMS	ESD	IEC/EN 61000-4-2	Contact ±4kV (A, B port) Perf. Criteria B
		IEC/EN 61000-4-2	Contact ±8kV (see Fig.2, A, B port) Perf. Criteria B
	EFT	IEC/EN 61000-4-4	±2kV (see Fig.2, A,B port) Perf. Criteria B
	Surge	IEC/EN 61000-4-5	±2kV (Bare component, A, B port) Perf. Criteria B
		IEC/EN 61000-4-5	±4kV (see Fig.2, A, B port) Perf. Criteria B
	CS	IEC/EN 61000-4-6	3Vr.m.s Perf. Criteria A

### Application Precautions

1. Please read the instructions carefully before use; contact our technical support if you have any problem;
2. Do not use the product in hazardous areas;
3. Use DC power supply for the product and 220V AC power supply is prohibited;
4. Do not dismount and assemble the product without permission to avoid failure or malfunction of equipment;

### After-sales service

1. Ex-factory inspection and quality control have been strictly conducted for the product; if there occurs abnormal operation or possibility of failure of internal module, please contact the local representative or our technical support;
2. The warranty period for the product is 3 years as calculated from the date of delivery. If any quality problem occurs under normal use within the warranty period, the product can be repaired or changed for free.

### Applied circuit

Refer to the RS485 Industrial Bus Interface Isolating Module Application Manual.

### Design Reference

#### 1. Typical application circuit

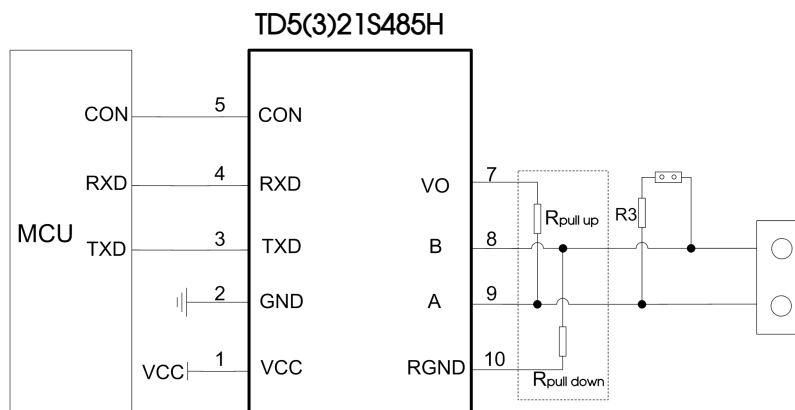

Fig.1

As shown in Figure 1, TD5(3)21S485H isolated transceiver module typical connection circuit, which TD521S485H module must use 5V power supply, the module TXD, RXD and CON pin interface matching level of 5V, does not support 3.3V system level, TD321S485H module must use 3.3V power supply, the module TXD, RXD and CON pin interface matching level of 3.3V, does not support 5V system level.

R pull-up, R pull-down for the external reserve pull-down resistor, according to the actual situation to choose whether the need for external pull-down resistor. TD5 (3) 21S485H Isolated transceiver module has built-in 24kΩ pull-down resistor, under normal circumstances the use of internal pull-up, pull-down resistor to meet the demand.

#### 2. Recommended port protection circuit

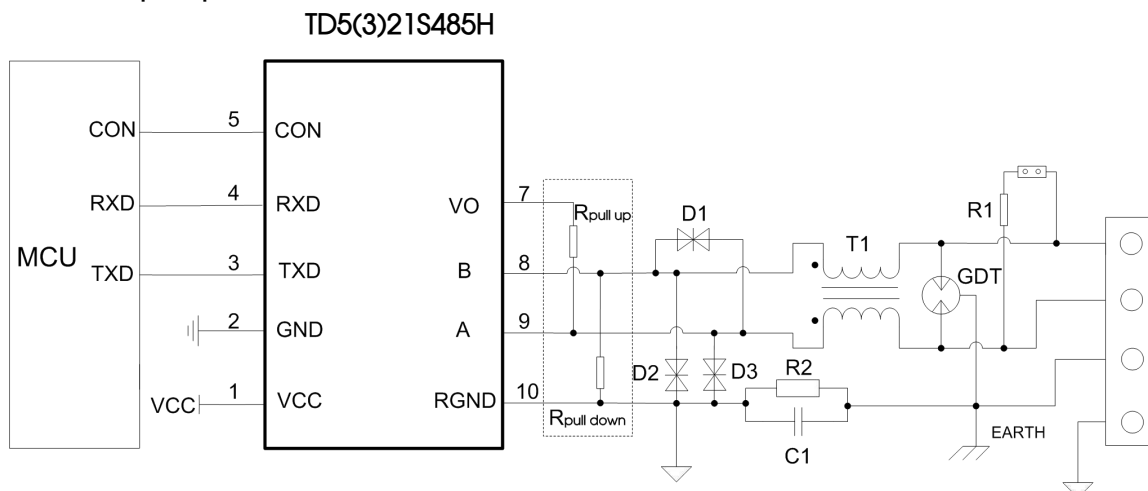

Fig.2

Notes: Twisted pair shield grounded reliably.

Parameter declaration:

Components	Recommended parameters	Components	Recommended parameters
R1	120Ω	R2	1MΩ
C1	102,2kV	D1	SMBJ12CA
T1	ACM2520-301-2P	D2、D3	SMBJ6.5CA
GDT	S30-A90X	R <sub>pull up</sub> 、R <sub>pull down</sub>	Select the appropriate resistance matching network

As the module internal A / B line comes with ESD protection, so users generally apply to the environment in good circumstances without additional ESD protection devices, as shown in Figure 1, the typical connection circuit. But if the application environment is relatively poor (such as high voltage power, lightning and other environments), it is recommended that users must be in the module A / B line side plus TVS tube, common mode inductors, Gas discharge tube, shielded twisted pair or the same network single point Earth and other protective measures. Therefore, the recommended application circuit shown in Figure 2, the recommended parameters as shown in the table. Recommended circuit diagram and parameter values for reference only, according to the actual situation to determine whether the need for circuit diagram of the device and the appropriate parameter values.

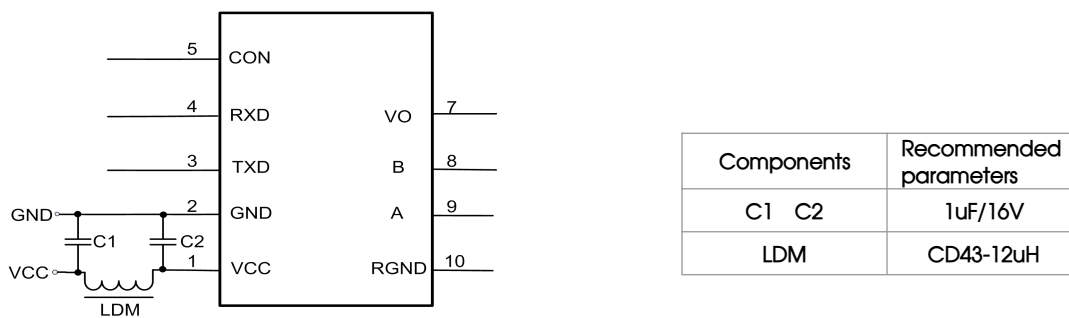

Fig.3

### 3. Precautions

- 1) Hot swapping is not supported.
- 2) TD521S485H is not compatible with 3.3V TTL level; TD321S485H is not compatible with 5V TTL level
- 3) Module 6 feet are not drawn, this pin is left when the pin 10 is not used.
- 4) Data transmission line, please use shielded twisted pair, the same network of shielding the single point of the earth.
- 5) From the truth table characteristics can be seen, The series of embedded isolated RS-485 transceiver module is in the CON pin is low to send data, CON pin is high when receiving data, and the general 485 transceiver chip transceiver control level is the opposite. Therefore, if the customer wants to change with the ordinary 485 transceiver chip transceiver control level is the same, Then recommend the customer in the MCU and CON feet between a transistor reverse circuit.
- 6) From the truth table characteristics, the series of embedded isolated RS-485 transceiver module when the A / B line differential voltage greater than or equal to -50mV, the module receiving level is high; when the A / B line differential voltage is less than or equal to -200mV , The module receiving level is low; when the A / B line differential voltage is greater than -200mV and less than -50mV, the module receiving level is uncertain, the design to ensure that the module is not receiving the state. So the user in the RS-485 network design or application, according to the actual situation to decide whether to add 120Ω termination resistor. Principle of use: Regardless of whether the RS-485 network is static or dynamic, it is necessary to ensure that the differential voltage of A / B line is not between -200mV and -50mV. Otherwise, the data communication error will occur.

4. For more information, please find the application note on [www.mornsun-power.com](http://www.mornsun-power.com)

Dimensions and Recommended Layout

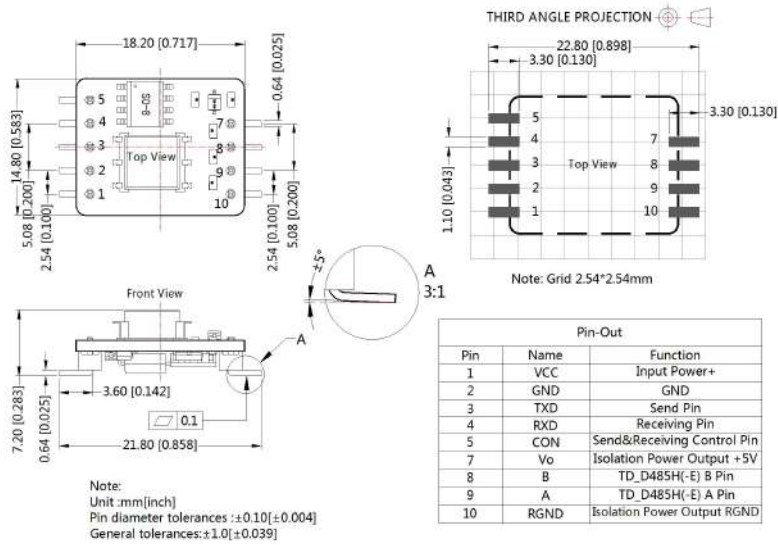

Package diagram:

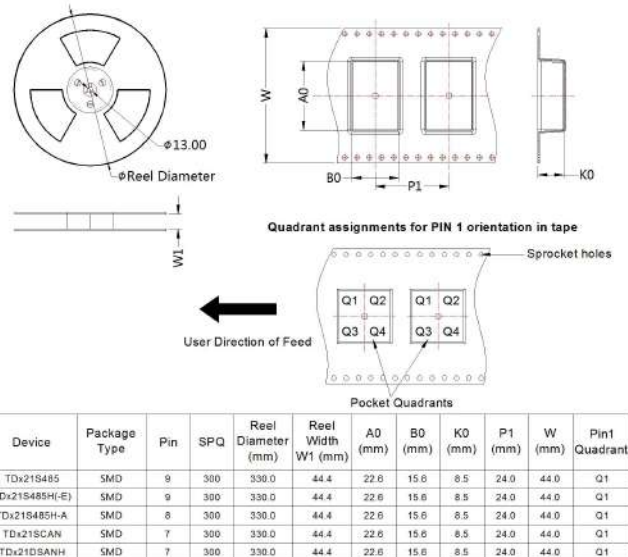

Notes:

1. Packing information please refer to Product Packing Information which can be downloaded from [www.mornsun-power.com](http://www.mornsun-power.com). Packing bag number: 58240012;
2. Unless otherwise specified, data in this datasheet should be tested under the conditions of Ta=25°C, humidity<75% when inputting nominal voltage and outputting rated load;
3. PCB surface may be micro-color difference, is a normal phenomenon, does not affect the use of the product;
4. All index testing methods in this datasheet are based on our Company's corporate standards;
5. The performance indexes of the product models listed in this datasheet are as above, but some indexes of non-standard model products will exceed the above-mentioned requirements, and please directly contact our technician for specific information;
6. We can provide product customization service;
7. Products are related to laws and regulations: see "Features" and "EMC".
8. Our products shall be classified according to ISO14001 and related environmental laws and regulations, and shall be handled by qualified units

Mornsun Guangzhou Science & Technology Co., Ltd.

Address: No. 5, Kehui St. 1, Kehui Development Center, Science Ave., Guangzhou Science City, Luogang District, Guangzhou, P. R. China  
Tel: 86-20-38601850-8801 Fax: 86-20-38601272 E-mail: info@mornsun.cn